

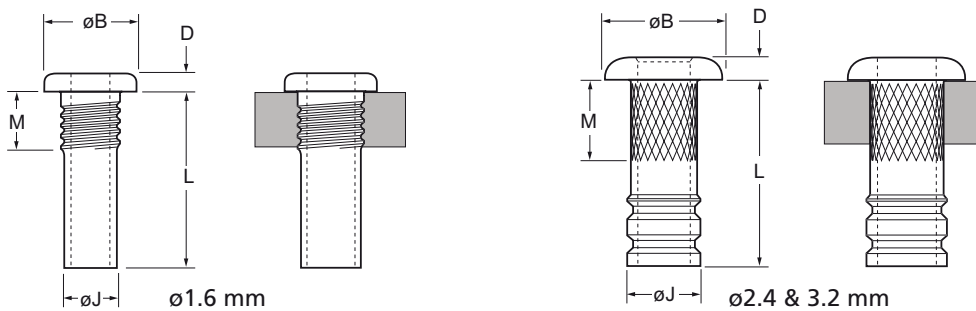

| English      | Français   | Deutsch                | Italiano    | Español        |
|--------------|------------|------------------------|-------------|----------------|
| Dome head    | Tête plate | Flachrundkopf          | Testa tonda | Cabeza alomada |
| Brass*       | Laiton*    | Kupfer-Zink Legierung* | Ottone*     | Latón*         |
| Tin plated** | Etamé**    | verzinkt**             | Stagnato**  | Estañado**     |

\*: BS EN 12166 CW 508L DIN 17660 CuZn37

\*\* : We recommend tin plated parts 1107 Series are installed within 9 months from the date they were produced.  
 Nous conseillons d'utiliser les pièces en laiton étamé du série 1107 sous un délai de 9 mois après la date de production.  
 Wir empfehlen, verzinkte Nieten der Serie 1107 innerhalb 9 Monaten nach Produktionsdatum zu verarbeiten.  
 Raccomandare di utilizzare i prodotti stagnati serie 1107 entro 9 mesi a decorrere dalla data di fabbricazione.  
 Recomendamos utilizar sus piezas estañadas serie 1107 antes de 9 meses desde la fecha de su fabricación.

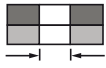

| Ø              |  |      | ØB   | D    | L    | ØJ   | M    | No. of grooves<br>cannelures<br>Rillen<br>rigature<br>aros | Fasteners per pod<br>Nombre de rivets par<br>chargeur /<br>Niete pro Magazin /<br>Rivetti per caricatore /<br>Uds./carga<br>± 1 | Part No/ref |
|----------------|---|------|------|------|------|------|------|--|---|-------------|
|                | nom.  | min. |      |      |      |      |      |  |   |             |
| 1.6<br>(1/16") | 1.80  | 1.93 | 2.80 | 0.61 | 4.11 | 1.79 | 2.04 | 4  | 62  | 01107-00205 |
|                |   |      |      |      | 6.51 |      |      |  |   |             |
| 2.4<br>(3/32") | 2.62  | 2.74 | 4.15 | 0.94 | 8.36 | 2.60 | 3.43 | 2  | 33  | 01107-00310 |
|                |   |      |      |      | 9.96 |      |      | 3  | 28  | 01107-00312 |
| 3.2<br>(1/8")  | 3.38  | 3.51 | 5.52 | 1.15 | 9.96 | 3.36 | 3.43 | 3  | 26  | 01107-00412 |

all dimensions in mm / en millimètres / alle Maße in mm / in millimetri / en milímetros