

TEXTRON Fastening Systems

Avdel® Blind Fastening & Automation Systems

Instruction Manual



74201 model

Threaded Insert Power Tool

Contents

Safety Rules	4	Priming continued	
		Priming Procedure	18
Specifications		Fault Diagnosis	
Tool Specification	5	Symptom, Possible Cause and Remedy	19-20
Tool Dimensions	5		
Intent of Use	6		
Putting into Service			
Air Supply	7		
Force Adjustment	7		
Operating Procedure	7		
Nose Assemblies			
Fitting Instructions	8		
Servicing Instructions	8		
Selection	9		
Servicing the Tool			
Daily / Weekly	10		
Molykote 55m Lithium Grease Safety Data	10		
Service Kit	11		
Maintenance			
Tool Servicing	12		
Pneumatic Cylinder	12		
Rod Guide	12		
Trigger	12		
Swivel Air Inlet	12		
Differential Valve	13		
Head Assembly	13		
Rear Casing	13		
Distributor	13		
Hydraulic Piston and Air Motor Assembly	13		
General Assembly of Base Tool			
General Assembly	14		
Parts List	15		
Pressure Switch Assembly	16		
Pressure Switch Removal	16		
Priming			
Oil Details	18		
Hyspin VG 32 Oil Safety Data	18		

Warranty

Textron Fastening Systems installation tools carry a 12 month warranty against defects caused by faulty materials or workmanship, the warranty period commencing from the date of delivery confirmed by invoice or delivery note.

The warranty applies to the user/purchaser when sold through an authorised outlet, and only when used for the intended purpose. The warranty is invalidated if the installation tool is not serviced, maintained and operated according to the instructions contained in the Instruction and Service Manuals.

In the event of a defect or failure, and at its sole discretion, Textron Fastening Systems undertakes only to repair or replace faulty components.

Textron Fastening Systems policy is one of continuous product development and improvement and we reserve the right to change the specification of any product without prior notice.

Safety Rules

This instruction manual must be read with particular attention to the following safety rules, by any person installing, operating, or servicing this tool.

- 1 Do not use outside the design intent.
- 2 Do not use equipment with this tool/machine other than that recommended and supplied by Textron Fastening Systems.
- 3 Any modification undertaken by the customer to the tool/machine, nose assemblies, accessories or any equipment supplied by Textron Fastening Systems or their representatives, shall be the customer's entire responsibility. Textron Fastening Systems will be pleased to advise upon any proposed modification.
- 4 The tool/machine must be maintained in a safe working condition at all times and examined at regular intervals for damage and function by trained competent personnel. Any dismantling procedure shall be undertaken only by personnel trained in Textron Fastening Systems procedures. Do not dismantle this tool/machine without prior reference to the maintenance instructions. Please contact Textron Fastening Systems with your training requirements.
- 5 The tool/machine shall at all times be operated in accordance with relevant Health and Safety legislation. In the U.K. the "Health and Safety at Work etc. Act 1974" applies. Any question regarding the correct operation of the tool/machine and operator safety should be directed to Textron Fastening Systems.
- 6 The precautions to be observed when using this tool/machine must be explained by the customer to all operators.
- 7 Always disconnect the airline from the tool/machine inlet before attempting to adjust, fit or remove a nose assembly.
- 8 Do not operate a tool/machine that is directed towards any person(s) or the operator.
- 9 Always adopt a firm footing or a stable position before operating the tool/machine.
- 10 Ensure that vent holes do not become blocked or covered.
- 11 The operating pressure shall not exceed 7 bar.
- 12 Do not operate the tool if it is not fitted with a complete nose assembly or swivel head unless specifically instructed otherwise.
- 13 Care shall be taken to ensure that spent stems are not allowed to create a hazard.
- 14 If the tool is fitted with a stem collector, it must be emptied when half full.
- 15 If the tool is fitted with a stem deflector, it should be rotated until the aperture is facing away from the operator and other person(s) working in the vicinity.
- 16 When using the tool, the wearing of safety glasses is required both by the operator and others in the vicinity to protect against fastener ejection, should a fastener be placed 'in air'. We recommend wearing gloves if there are sharp edges or corners on the application.
- 17 Take care to avoid entanglement of loose clothes, ties, long hair, cleaning rags etc. in the moving parts of the tool which should be kept dry and clean for best possible grip.
- 18 When carrying the tool from place to place keep hands away from the trigger/lever to avoid inadvertent start up.
- 19 Excessive contact with hydraulic fluid oil should be avoided. To minimize the possibility of rashes, care should be taken to wash thoroughly.
- 20 C.O.S.H data for all hydraulic oils and lubricants is available on request from your tool supplier.

Specifications

Tool Specification

Air Pressure	Minimum - Maximum	5-7 bar (75-100 lbf/in ²)
Free Air Volume Required	@ 5 bar/75 lbf/in ²	7.5 litres (.26 ft ³)
Stroke	Maximum	7 mm (.276 in)
Motor Speed	Spin On	2000 rpm
	Spin Off	2000 rpm
Pull Force	@ 5 bar/75 lbf/in ²	17.65 kN (3967.20 lbf)
Cycle time	Approximately	2.5 seconds
Noise Level	Less than	75 dB(A)
Weight	Without nose equipment	2.1 kg (4.63 lb)
Vibration	Less than	2.5 m/s ² (8 ft/s ²)
Placing Features	Inserts	M3 - M8

Tool Dimensions

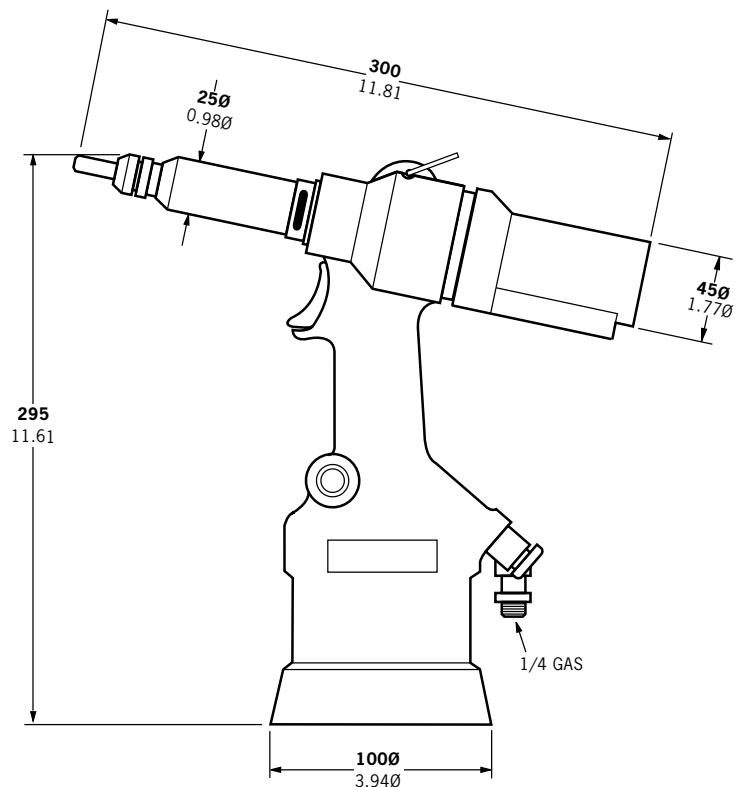

Dimensions shown in **bold** are millimetres. Other dimensions are in inches.

Intent of Use

The 74201 hydro-pneumatic tool is designed to placing Textron threaded inserts and is ideal for batch or flow-line assembly in a wide variety of applications throughout all industries.

The tool works on a principle of adjustment of the force rather than the stroke. The advantage lies in the fact that it is possible to place the same insert (of the specified tightening thickness) in materials of different thicknesses, after setting the tool for the greatest thickness.

The tool is available in the basic configuration using code 74201-12000.

In addition there are nose assembly kits for the type and size of the insert which is to be placed.

(see selection tables on page 9).

The tables also give the complete tool code (basic tool plus nose assembly kits).

Nose assemblies must be fitted as described on page 8.

Putting into Service

Air Supply

All tools are operated with compressed air at an optimum pressure of 5.5 bar. We recommend the use of pressure regulators and automatic cooling/filtering systems on the main air supply. These should be mounted within 3 metres from the tool (see diagram below) to ensure maximum tool life with minimum tool maintenance.

The flexible hoses should have a minimum working effective pressure rating of 150% of the maximum pressure produced in the system or 10 bar, whichever is the highest. Air hoses should be oil resistant, have an abrasion resistant exterior and should be armoured where operating conditions may result in hoses being damaged. All air hoses **MUST** have a minimum bore diameter of 6.4 millimetres or 1/4 inch.

Read servicing daily details page 10.

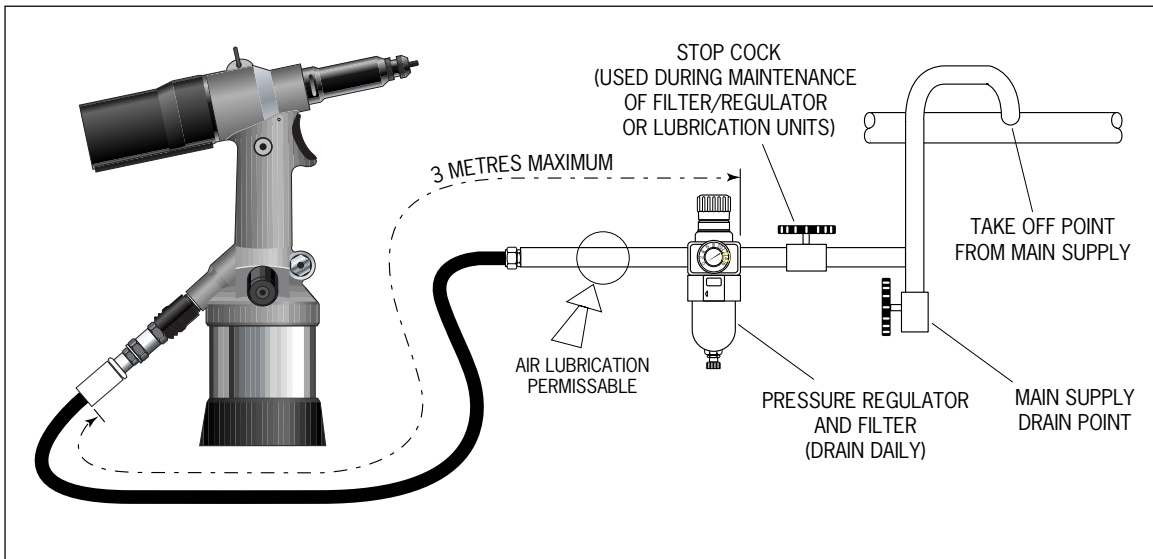

Force Adjustment

After fitting the appropriate nose assembly for the insert to be placed, connect the tool to the air supply hose.

Using the 3mm allen key, unscrew the Regulator **93*** a few turns until it is pressing the Trigger **40** and there is no pull on the spindle.

To confirm this, screw an insert on the spindle (press to make it spin on) and press the trigger. The insert is not deformed and the tool begins to spin off.

To adjust the pull force, turn the Regulator **93*** less than a turn (approx half turn) and repeat the cycle with the same insert (at each trial cycle, increase turning Regulator **93*** until deformation of the insert with out thickness is obtained. At this stage, less force is needed to deform the insert).

After a successful trial insert deformation, test the thickness and increase the force if the insert is not sufficiently shaped.

Usually, this last adjustment requires a slight increase in the tightening of Regulator **93***.

The tool is now ready to operate.

When dealing with different thicknesses, set it for the greatest thickness.

93* See page 16 Pressure Switch Assembly.

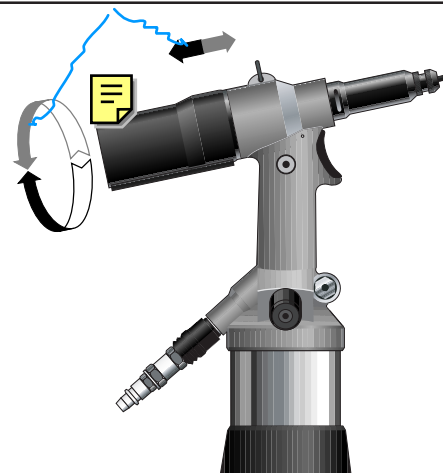

Operating Procedure

- Connect the tool to air supply. Adjust the pull force.
- Offer up insert, lip first to drive screw. A slight pressure will start the motor and automatically thread the insert up against nose tip and stop.
- Insert fastener into application squarely.
- Fully depress trigger. This will both place insert into the application and disengage it from the drive screw.

Do not connect the tool to the air supply until all the components are put in place, as indicated in the drawing on page 14 Item numbers in **bold** refer to the General Assembly drawing and parts list (pages 14-15).

Nose Assemblies

It is essential that the correct nose assembly is fitted prior to operating the tool. If you know the code for your complete, original tool, or the details of the fastening systems which are to be used, you will be able to order a new complete nose assembly using the selection tables on page 9.

Fitting Instructions

IMPORTANT
The air supply must be disconnected when fitting or removing nose assemblies unless specifically instructed otherwise.

Item numbers in **bold** refer to illustration below:

- If still fitted, remove the nose casing and the adaptor nut.
- Insert Drive Shaft **4** into spindle.
- Fit Drive Screw **3** onto Drive Shaft **4**.
- Insert Reducing Sleeve **5** (if specified) into the adaptor nut.
- Screw the adaptor nut onto the spindle.
- Hold the spindle with a spanner* and tighten the adaptor nut clockwise.
- While holding the adaptor nut with the spanner*, tighten the lock nut anti-clockwise.
- Screw on the nose casing and Nose Tip **1** with the nose tip Lock Nut **2**.
- The reverse operation is carried out for equipment removal.

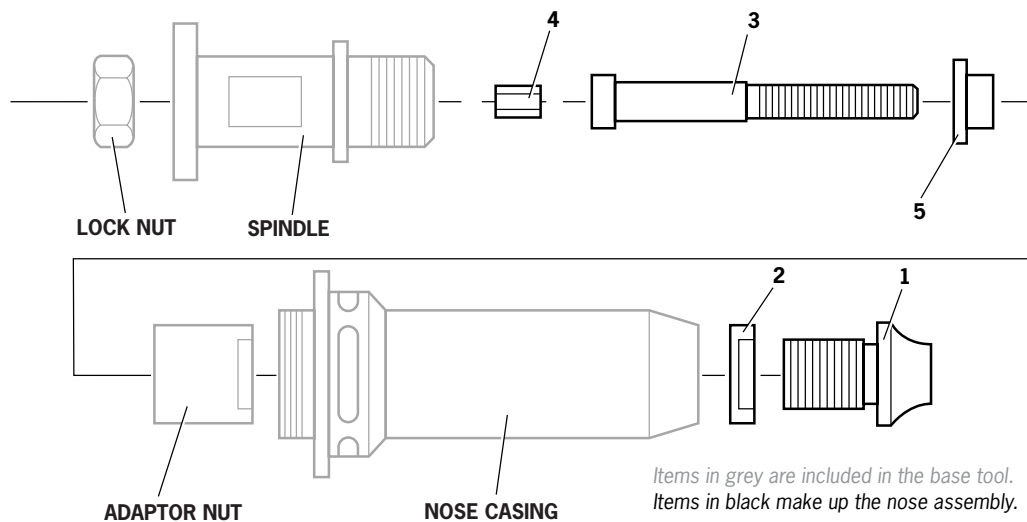

- With the tool still disconnected from the air supply, position Nose Tip **1** on the nose casing and lock it with Lock Nut **2** so that the insert lines up with the end of Drive Screw **3**.
- Lock the nose tip lock nut by turning clockwise with a spanner*.
- Remove the insert from drive screw.

IMPORTANT
Do not press against the drive screw when tool is connected to the air supply with no insert in as the drive screw starts to run with axial force.

Servicing Instructions

Nose assemblies should be serviced at weekly intervals (see page 10)..

- Remove the complete nose assembly using the reverse procedure to the 'Fitting Instructions'.
- Any worn or damaged parts should be replaced with new parts.
- Particularly check wear on the Drive Screw **3**.
- Assemble according to fitting instructions (see above).

* Refers to items included in the 74201 Service Kit. For complete list see page 11.

Nose Assemblies

Selection

Nose tips vary in shape according to the insert type. Each nose assembly represents a unique assembly of components which can be ordered individually. All nose assemblies also include a nose tip Lock Nut **2** (part number **07555-00901**). Component numbers refer to the illustration on the opposite page. We recommend some stock as items will need regular replacement. Read the Nose Assemblies Servicing Instructions opposite carefully.

			COMPONENT NUMBERS			
INSERT SIZE	COMPLETE TOOL	NOSE ASSEMBLY	1	3	4	5
LARGE FLANGE INSERTS (9698,FS58,9408,9418,9498) + STANDARD NUTSERT® (9500) + SQUARESERT® (GK08) + EUROSERT® (GJ08)						
M3	74201-00083	07555-09883	07555-00903	07555-09003	07555-01003	07555-09103
M4	74201-00084	07555-09884	07555-00904	07555-09004	07555-01004	07555-09104
M5•	74201-00085	07555-09885	07555-00905	07555-09005	07555-01005	07555-09105
M5••	74201-00485	07555-09185	07555-00915	07555-09005	07555-01005	07555-09105
M6	74201-00086	07555-09886	07555-00906	07555-09006	07555-01006	07555-09106
M8	74201-00088	07555-09888	07555-00908	07555-09008	07555-01008	07555-09108
4 UNC	74201-00054	07555-09854	07555-00854	07555-09054	07555-00754	07555-09154
6 UNC	74201-00056	07555-09856	07555-00856	07555-09056	07555-00756	07555-09156
8 UNC	74201-00058	07555-09858	07555-00858	07555-09058	07555-00758	07555-09158
10 UNC	74201-00050	07555-09850	07555-00850	07555-09050	07555-00750	07555-09150
1/4 UNC	74201-00048	07555-09848	07555-00848	07555-09048	07555-00748	07555-09148
5/16 UNC	74201-00040	07555-09840	07555-00840	07555-09040	07555-00740	07555-09140
10 UNF	74201-00070	07555-09870	07555-00850	07555-09070	07555-00750	07555-09150
1/4 UNF	74201-00068	07555-09868	07555-00848	07555-09068	07555-00748	07555-09148
5/16 UNF	74201-00060	07555-09860	07555-00840	07555-09060	07555-00740	07555-09140
3/16 BSW	74201-00016	07555-09816	07555-00850	07555-09016	07555-00750	07555-09150
1/4 BSW	74201-00018	07555-09818	07555-00848	07555-09018	07555-00748	07555-09148
THIN SHEET NUTSERT® (9468, FS38, 9650, 9488)						
M3	74201-00183	07555-09983	07555-00993	07555-09003	07555-01003	07555-09103
M4	74201-00184	07555-09984	07555-00994	07555-09004	07555-01004	07555-09104
M5	74201-00185	07555-09985	07555-00995	07555-09005	07555-01005	07555-09105
M6	74201-00186	07555-09986	07555-00996	07555-09006	07555-01006	07555-09106
M8	74201-00188	07555-09988	07555-00998	07555-09008	07555-01008	07555-09108
4 UNC	74201-00154	07555-09954	07555-00954	07555-09054	07555-00754	07555-09154
6 UNC	74201-00156	07555-09956	07555-00956	07555-09056	07555-00756	07555-09156
8 UNC	74201-00158	07555-09958	07555-00958	07555-09058	07555-00758	07555-09158
10 UNC	74201-00150	07555-09950	07555-00950	07555-09050	07555-00750	07555-09150
1/4 UNC	74201-00148	07555-09948	07555-00948	07555-09048	07555-00748	07555-09148
10 UNF	74201-00170	07555-09970	07555-00950	07555-09070	07555-00750	07555-09150
1/4 UNF	74201-00168	07555-09968	07555-00948	07555-09068	07555-00748	07555-09148
5/16 UNF	74201-00160	07555-09960	07555-00940	07555-09060	07555-00740	07555-09140
3/16 BSW	74201-00116	07555-09916	07555-00950	07555-09016	07555-00750	07555-09150
1/4 BSW	74201-00118	07555-09918	07555-00948	07555-09018	07555-00748	07555-09148
OBA	74201-00130	07555-09930	07555-00996	07555-09030	07555-01006	07555-09106
2BA	74201-00132	07555-09932	07555-00950	07555-09032	07555-00750	07555-09150
4BA	74201-00134	07555-09934	07555-00934	07555-09034	07555-00756	07555-09134
SUPERSERT® - OPEN AND CLOSED END (FB)						
M3	74201-00283	07555-09583	07555-07103	07555-09003	07555-01003	07555-09103
M4	74201-00284	07555-09584	07555-07104	07555-09004	07555-01004	07555-09104
M5	74201-00285	07555-09585	07555-07105	07555-09005	07555-01005	07555-09105
M6	74201-00286	07555-09586	07555-07106	07555-09006	07555-01006	07555-09106
M8	74201-00288	07555-09588	07555-07108	07555-09008	07555-01008	07555-09108
8 UNC	74201-00258	07555-09558	07555-07158	07555-09058	07555-00758	07555-09158
10 UNC	74201-00250	07555-09550	07555-07150	07555-09050	07555-00750	07555-09150
1/4 UNC	74201-00248	07555-09548	07555-07148	07555-09048	07555-00748	07555-09148
8 UNF	74201-00278	07555-09578	07555-07158	07555-09078	07555-00758	07555-09158
10 UNF	74201-00270	07555-09570	07555-07150	07555-09070	07555-00750	07555-09150
1/4 UNF	74201-00268	07555-09568	07555-07148	07555-09068	07555-00748	07555-09148
HEXSERT® (9688)						
M3	74201-00683	07555-09283	07555-08103	07555-09003	07555-01003	07555-09103
M4	74201-00684	07555-09284	07555-08104	07555-09004	07555-01004	07555-09104
M5	74201-00685	07555-09285	07555-08105	07555-09005	07555-01005	07555-09105
M6	74201-00686	07555-09286	07555-08106	07555-09006	07555-01006	07555-09106
M8	74201-00688	07555-09288	07555-00998	07555-09008	07555-01008	07555-09108

• Places all inserts listed in this section except M5 large flange Thin Sheet Nutsert®

•• Places M5 large flange Thin Sheet Nutsert® 09698-00516 ONLY

Servicing the Tool

Regular servicing should be carried out and a comprehensive inspection performed annually or every 500,000 cycles, whichever is sooner.

I M P O R T A N T

**The employer is responsible for ensuring that tool maintenance instructions are given to the appropriate personnel.
The operator should not be involved in maintenance or repair of the tool unless properly trained.**

Daily

- Daily, before use or when first putting the tool into service, pour a few drops of clean, light lubricating oil into the air inlet of the tool if no lubricator is fitted on air supply. If the tool is in continuous use, the air hose should be disconnected from the main air supply and the tool lubricated every two to three hours.
- Check for air leaks. If damaged, hoses and couplings should be replaced by new items.
- If there is no filter on the pressure regulator, bleed the air line to clear it of accumulated dirt or water before connecting air hose to tool.
- Check that the nose assembly is correct.
- Check the stroke of the tool is adequate to place selected insert. (See Force Adjustment page 7).
- Inspect the drive screw in the nose assembly for wear or damage. If any, renew.

Weekly

- Check for oil leaks and air leaks on air supply hose and fittings.

Molykote 55m Lithium Grease Safety Data

Grease can be ordered as a single item, the part number is shown in the Service Kit page 11.

First Aid

SKIN: Wipe off and wash with soap and water.

INGESTION: No adverse effects are normally expected.
Treat symptomatically.

EYES: Irritant but not harmful. Irrigate with water and seek medical attention.

Environment

Scrape up for incinerating or disposal on approved site.

Fire

FLASH POINT: 101°C
Not classified as flammable.
Suitable extinguishing media: Carbon dioxide, foam, dry powder or fine water spray.

Handling

Plastic or rubber gloves should be worn.

Storage

Away from heat and oxidising agent.

Servicing the Tool

Service Kit

For all servicing we recommend the use of the Service Kit (part number 74201-99990) supplied in its own plastic case.

74201-99990 SERVICE KIT			Spanners are specified in inches and across flats unless otherwise stated		
ITEM PART N°	DESCRIPTION	N° OFF	ITEM PART N°	DESCRIPTION	N° OFF
07900-00618	PUSHER	1	07900-00393	14mm/15mm SPANNER	1
07900-00619	GUIDE BUSH	1	07900-00409	12mm/13mm SPANNER	1
07900-00478	Ø 3mm PIN PUNCH	1	07900-00626	11mm SPANNER	1
07900-00624	Ø 4mm PIN PUNCH	1	07900-00469	2.5mm ALLEN KEY	1
07900-00157	INTERNAL CIRCLIP PLIERS	1	07900-00351	3mm ALLEN KEY	1
07900-00161	EXTERNAL CIRCLIP PLIERS	1	07900-00224	4mm ALLEN KEY	1
07900-00625	SOFT MALLET	1	07900-00225	5mm ALLEN KEY	1
07900-00623	25mm SOCKET	1	07900-00620	12mm ALLEN KEY	1
07900-00006	SPATULA	1	07900-00456	T BAR	1
07900-00434	32mm SPANNER	1	07992-00075	MOLYKOTE 55M (100 gm TUBE)	1
07900-00621	28mm SPANNER	1	07900-00627	PLASTIC CASE	1
07900-00637	17mm SPANNER	1	07900-00632	17mm/19mm SPANNER	2
07900-00643	PUSHER KNOB	1			

Maintenance

Every 500,000 cycles the tool should be completely dismantled and components replaced where worn, damaged or when recommended. All 'O' rings and seals should be replaced with new ones and lubricated with Molykote 55M grease before assembling.

IMPORTANT

Safety Instructions appear on page 4.

**The employer is responsible for ensuring that tool maintenance instructions are given to the appropriate personnel.
The operator should not be involved in maintenance or repair of the tool unless properly trained.**

The airline must be disconnected before any servicing or dismantling is attempted unless specifically instructed otherwise.

It is recommended that any dismantling operation be carried out in clean conditions. Before proceeding with dismantling, empty the oil from the tool. Remove Oil Plug **35**, Oil Seal Washer **36**, Bleed Screw **10** and Oil Seal Bleed Washer **9** from the handle assembly and drain the oil into a suitable container.

Prior to dismantling the tool it is necessary to remove the nose assembly. For simple removal instructions see the nose assemblies section, pages 8-9.

Tool Servicing

For total tool servicing we advise that you proceed with dismantling of sub-assemblies in the order shown below.

Pneumatic Cylinder

- Remove Rubber Base **74**.
- Place tool, base uppermost in vice fitted with soft jaws.
- Using a spanner*, unscrew Base Casing **75**. Pneumatic Piston **68** should move upward under Spring **65** pressure (it may be necessary to exert hand pressure to Pneumatic Piston **68**).
- Remove 'O' Ring **71**.
- Withdraw Pneumatic Piston **68**.
- Remove Lip Seal **69** and 'O' Rings **78** and **28**.
- Hold Pneumatic Piston Rod **66** in soft vice jaws to avoid scratching rod diameter.
- Separate Pneumatic Piston Rod **66** from Pneumatic Piston **68** by unscrewing piston rod fastening Bolt **76** using a spanner*.
- Inspect Air Supply Tube **79** for damage or distortion. (Air tube is screwed internally into handle and set in position with Loctite 222) If it is necessary to remove air tube, the base of the air tube will require warming to a temperature of 100°C to soften the Loctite adhesive. The Air Supply Tube **79** can then be unscrewed from the handle using an Allen key*.
- Check Spring **65** is not distorted or damaged.
- Replace any damaged seals and springs.
- Assembly is in reverse order to dismantling.
- To replace Piston Rods **67**: they are screwed and locked with Loctite 222 into Base Casing **75**. To remove them it may be necessary to warm up the base of the piston rod to 100°C to soften Loctite 222. The piston rods can be then removed with a vice.

Rod Guide

- With tool in upside down position in vice, unscrew Rod Guide **62** using a spanner* and T-bar*.
- Withdraw Rod Guide **62**.
- Unscrew Adaptor Nut **64** using an Allen key*, remove Lip Seal **63** and 'O' Ring **61**.
- Remove 'O' Ring **60**.
- Replace any damaged seals.
- Assembly is in reverse order to dismantling.

Trigger

- With tool held in vice, remove Pivot Pin **38** using a pin punch*.
- Remove Trigger **40**, Roller Pin **42**, Roller **41** and Push Wedge **39**.
- Gently push on the head of Trigger Rod **43** and remove together with 'O' Rings **48** and **44**, Guide **45**, Lip Seal **46** and Valve Locking Plug **47**.
- Assembly is in reverse order to dismantling. Ensure lip of Lip Seal **46** is towards head of tool.

Swivel Air Inlet (74200-12700)

- Remove Flexible Rubber Cover **88**.
- Using flat spanner remove Air Supply Assembly **115** and Washer **51**.
- Unscrew Sleeve **70**.
- Using circlip pliers remove Circlip **97** and Sintered Filter **98**.
- Assemble in reverse order of dismantling.

* Refers to items included in the 74200 service kit. For complete list see page 11.
Item numbers in **bold** refer to the General Assembly drawing and parts list (pages 14-15).

Maintenance

Differential Valve

- Using special flat spanner* unscrew Adaptor Nut **58**, withdraw and remove Spring **54** and 'O' Ring **55**.
- Remove Threaded Pin **50** and Deflector **49**.
- Remove Silencer **59** using a spanner* and nylon Washer **51**.
- Push Valve Piston **57** out from its housing together with 'O' Rings **56**, **55**, **53** and **52**.
- Check 'O' Rings **56**, **53** and **52** for damage, Spring **54** for distortion and renew if required.
- Assemble in reverse order of dismantling.

Head Assembly

- Remove Nose Casing **1**, Adaptor Nut **2** and 'O' Ring **4**.
- Using spanners* remove Spindle Connector **3** and Locknut **6**.
- Remove Washers **11** and **99**.
- Remove 'O' Ring **4**.
- Renew any damaged seals.
- Assemble in reverse order of dismantling.

Rear Casing

- Using an Allen key* remove two Screws **33** securing Rear Casing **26** and pull off..
- Remove Silencer **25** from inside rear casing.
- Assembly in reverse order of dismantling.

Distributor

- Using an Allen key* remove two Screws **7**.
- Withdraw Distributor **27** together with Ball **18**, Pushrod **17** and Spring **15**, taking care not to drop Ball **18**.
- Hold Distributor **27** in soft jaw vice and using circlip pliers remove Circlip **21**.
- Remove Silencer **23** and Spring **22**.
- Pull out Piston **29** together with three 'O' Rings **28**.
- Using an Allen key* remove four countersunk socket head Screws **19** and withdraw Stroke Stop **16**.
- Pull out two Air Supply Tubes **32** and four 'O' Rings **31**.
- Renew any damaged seals.
- Assemble in reverse order of dismantling.

Hydraulic Piston and Air Motor Assembly (74200-12610)

- Wrap adhesive tape around Hydraulic Piston **14** thread and move assembly backwards slowly and firmly.
- Using circlip pliers* remove Circlip **11** and Front Seal **8**.
- Using two spanners* separate the Hydraulic Piston **14** from Air Motor Casing **24**. Shim Adjustment Ring **34**, Movement Pivot **5**, 'O' Ring **13** and Lip Seal **12** will come out with Hydraulic Piston **14**.
- Remove 'O' Rings **13** and Lip Seal **12**.
- Remove air motor assembly out of Air Motor Casing **24**, using circlip pliers* remove Circlip **107**, then tap Air Motor Casing **24** on bench to free components.
- Parts **100** to **113** can be pulled out as an assembly, taking care not to drop Pin **106**.
- Remove Bearing **108**, Planet Gear Spindle **100**, three Planets **101**, Planet Gear **109** and Spacer **102**.
- Using a soft mallet tap splined head of Rotor **111**.
- Bearing **110** and Front End Plate **103** will come out with Stator **104** and five Rotor Blades **105**. (Rotor **111** remains in place).
- Place Rear End Plate **112** in vice with soft jaws.
- Using a pin punch* tap centre of Rotor **111** to remove Bearing **113**. (turn Rotor **111** upside down and Bearing **113** will come out).
- When assembling air motor, rear side of Rotor **111** must just touch Rear End Plate **112** without any axial gap, (any existing gap will disappear when Bearing **113** is fully located).
- When inserting air motor into Air Motor Casing **24** carefully align parts so that Pin **106** locates in centre hole between spin on/off ports of Stator **104** and Rear End Plate **112**.
- When assembling Hydraulic Piston **14** onto air motor assembly, tighten parts by hand and blow air into one of the outer ports of air Motor Casing **24**, checking to see air motor rotates freely.
- When assembling front Lip Seal **12** ensure larger diameter faces rear of tool.
- Renew any damaged seals.
- Assemble in reverse order to dismantling.

Pressure Switch Removal

- See page 16.

IMPORTANT

**Check the tool against daily and weekly servicing.
Priming is ALWAYS necessary after the tool has been dismantled and prior to operating**

* Refers to items included in the 74200 Service Kit. For complete list see page 11.
Item numbers in **bold** refer to the General Assembly drawing and parts list (pages 14-15).

General Assembly of Base Tool 74201-12000

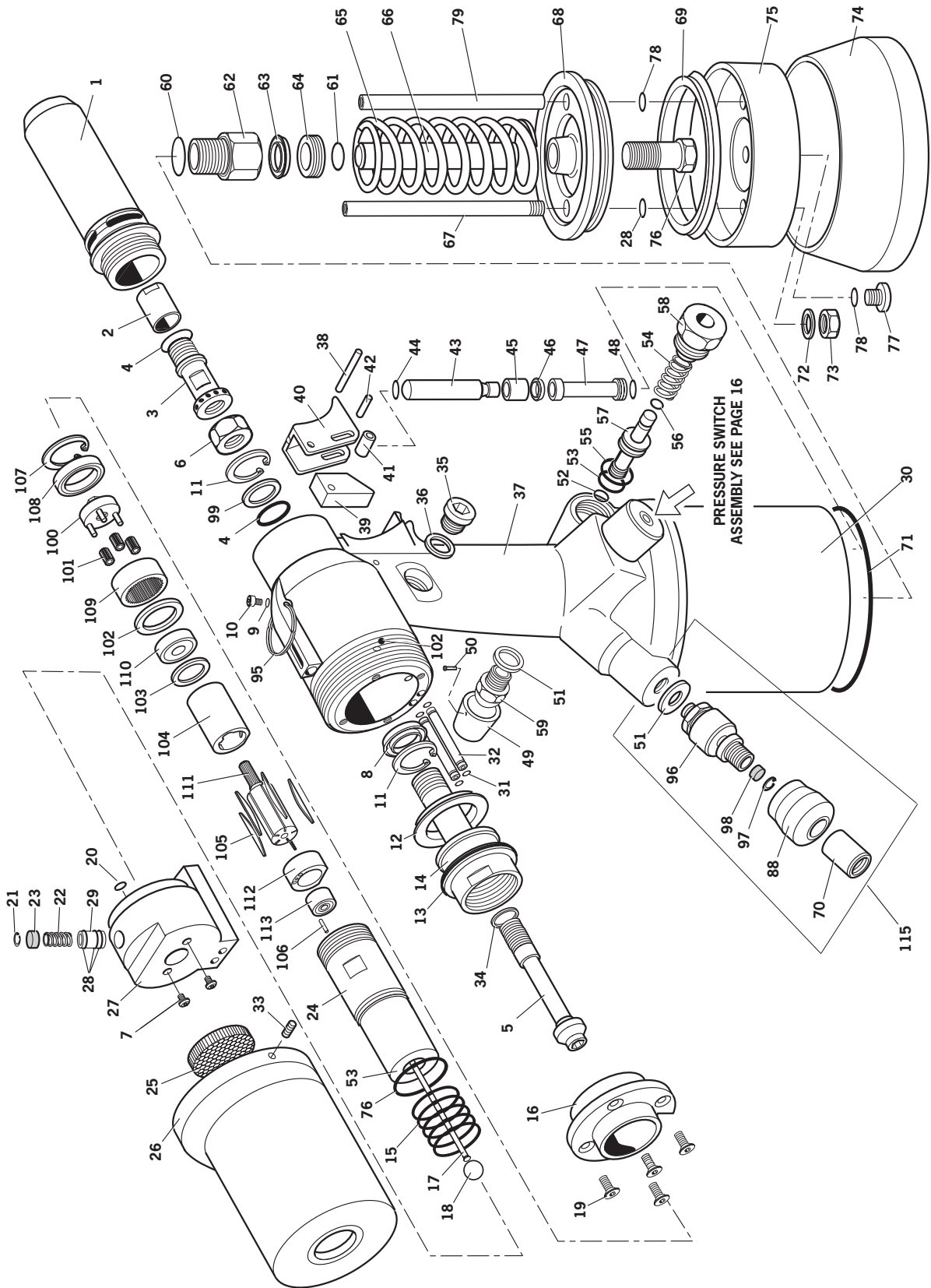

Parts List for 74201-12000

74201-12000 PARTS LIST											
ITEM	PART N°	DESCRIPTION	QTY	ITEM	PART N°	DESCRIPTION	QTY	ITEM	PART N°	DESCRIPTION	QTY
01	74200-12091	NOSE CASING	1	41	74200-12023	ROLLER	1	81	74201-12081	WASHER	1
02	74200-12092	ADAPTOR NUT (UP TO M8)	1	42	74200-12022	ROLLER PIN	1	82	74201-12082	PLUG	1
03	74200-12044	SPINDLE CONNECTOR	1	43	74200-12020	TRIGGER ROD	1	83	74201-12083	PISTON	1
04	07003-00028	O-RING	1	44	07003-000315	"O" RING	1	84	74201-12084	"O" RING	1
05	74200-12056	MOVEMENT PIVOT	1	45	74200-12019	GUIDE	1	85	74201-12085	LINER	1
06	07555-00803	LOCKNUT	1	46	74200-12018	LIP SEAL	1	86	74201-12086	CYLINDER	1
07	74201-12007	M4 SCREW	2	47	74201-12047	VALVE LOCKING PLUG	1	87	74201-12087	SPRING	1
08	07265-02004	FRONT SEAL	1	48	07003-00027	"O" RING	1	88	74290-03030	FLEXIBLE RUBBER COVER	1
09	74200-12049	OIL SEAL BLEED WASHER	1	49	74200-12302	DEFLECTOR	1	89	74201-12089	SPRING RETAINER	1
10	07001-00329	M5 BLEED SCREW	1	50	74200-12301	THREADED PIN	1	90	74201-12090	SPRING	1
11	74200-12099	CIRCLIP	2	51	74200-12033	1/8 WASHER	1	91	74201-12091	REAR CASING	1
12	74200-12053	LIP SEAL	1	52	07003-00046	"O" RING	1	92	74201-12092	CASING	1
13	74200-12121	"O" RING	1	53	07003-00026	"O" RING	2	93	74201-12093	REGULATOR	1
14	74201-12014	HYDRAULIC PISTON	1	54	74200-12104	SPRING	1	94	74201-12094	GRUB SCREW	1
15	74201-12015	SPRING	1	55	07003-00086	"O" RING	1	95	07265-03021	BRIDGE WASHER	1
16	74201-12016	STROKE STOP	1	56	07003-00040	"O" RING	1	96	74290-03031	AIR INLET BLOCK	1
17	74200-12078	PUSHROD	1	57	74200-12028	VALVE PISTON	1	97	74200-12097	CIRCLIP	1
18	74200-12079	BALL	1	58	74200-12027	ADAPTOR NUT	1	98	74200-12096	SINTERED FILTER	1
19	74290-03004	M4 SCREW	4	59	74200-12034	1/8 SILENCER	1	99	74200-12099	WASHER	1
20	74201-12020	"O" RING	1	60	07003-00100	"O" RING	1	100	74200-12063	PLANET GEAR SPINDLE	1
21	74201-12021	CIRCLIP	1	61	07003-00134	"O" RING	1	101	07555-09208	PLANET	3
22	74201-12022	SPRING	1	62	74200-12015	ROD GUIDE	1	102	74200-12066	SPACER	1
23	74201-12023	SILENCER	1	63	74200-12014	LIP SEAL	1	103	07555-09210	FRONT END PLATE	1
24	74201-12024	AIR MOTOR CASING	1	64	74200-12013	LOCK NUT	1	104	07555-09211	STATOR	1
25	74201-12025	SILENCER	1	65	07555-00205	SPRING	1	105	07555-09213	ROTOR BLADES	5
26	74290-03006	REAR CASING	1	66	74290-03018	PNEUMATIC PISTON ROD	1	106	07555-09216	PIN	1
27	74201-12027	DISTRIBUTOR	1	67	74290-03019	PISTON ROD	2	107	74200-12061	CIRCLIP	1
28	74290-03022	"O" RING	3	68	74290-03020	PNEUMATIC PISTON	1	108	74200-12062	BEARING	1
29	74201-12029	PISTON	1	69	74290-03021	LIP SEAL	1	109	74200-12065	PLANET GEAR	1
30	74290-03013	PNEUMATIC CYLINDER LINER	1	70	07265-03221	1/4 SLEEVE	1	110	07555-09206	BEARING	1
31	74200-12060	"O" RING	4	71	74290-03023	"O" RING	1	111	74200-12070	ROTOR	1
32	74290-03009	AIR SUPPLY TUBES	2	72	74290-03024	WASHER	2	112	07555-09214	REAR END PLATE	1
33	74290-03014	SCREW	2	73	74290-03025	NUT	2	113	07555-09215	BEARING	1
34	74200-12055	SHIM ADJUSTMENT RING	1	74	74290-03026	RUBBER BASE	1	114	74201-03001	INLET ASSEMBLY	1
35	07005-01274	OIL PLUG	1	75	74290-03027	BASE COVER	1	115	74201-03002	AIR SUPPLY ASSEMBLY	1
36	74290-03015	OIL SEAL WASHER	1	76	74290-03028	BOLT	1	116	74201-03004	DIFFERENTIAL UNIT	1
37	74201-12037	HANDLE	1	77	74200-12103	PLUG	1	117	74201-03003	PNEUMATIC MOTOR ASSEMBLY	1
38	74200-12026	PIVOT PIN	1	78	07003-00029	"O" RING	1				
39	74200-12024	PUSH WEDGE	1	79	74290-03029	AIR TUBE	1				
40	74200-12025	TRIGGER	1	80	74201-12080	"O" RING	3				

For Pressure Switch Assembly see page 16.

General Assembly of Base Tool 74201-12000

Pressure Switch Assembly

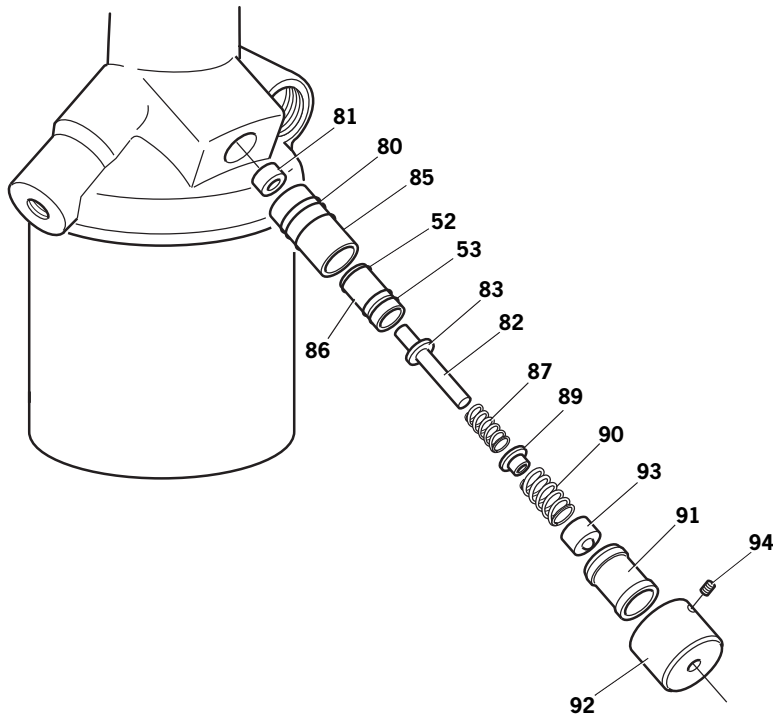

Pressure Switch Removal

- Pull out pressure switch assembly.
- Remove Grub Screw **94** and pull off Casing **92**.
- Hold Rear Casing **91** in soft jaw vice unscrew Liner **85** taking care not to damage surfaces.
- From Rear Casing **91** push out Regulator **93** together with with Spring **90**.
- Hold Liner **85** and pull out Spring Retainer **89** and Plug **82** together with Spring **87**, Piston **83**, Cylinder **86** and 'O' Rings **52** and **53** two off.
- Washer **81** will come off as Plug **82** is removed take care not to lose it.
- Pull off Spring Retainer **89** and Spring **87** from Plug **82**.
- Pull out Plug **82** and Piston **83** from within Cylinder **86**.
- Remove 'O' Rings **52** and **53** two off from Cylinder **86**.
- Replace any damaged seals or springs.
- Assemble in reverse order of dismantling.

Item numbers in **bold** refer to the General Assembly drawing and parts list (pages 14-15).

Notes

Notes

Notes

Priming

Priming is ALWAYS necessary after the tool has been dismantled and prior to operating. It may also be necessary to restore the full stroke after considerable use, when the stroke may be reduced and fasteners are not fully placed by one operation of the trigger.

Oil Details

The recommended oil for priming is Hyspin VG32 available in 0.5l (part number 07992-00002) or one gallon containers (part number 07992-00006). Please see safety data below.

Hyspin VG 32 Oil Safety Data

First Aid

SKIN:

Wash thoroughly with soap and water as soon as possible. Casual contact requires no immediate attention. Short term contact requires no immediate attention.

INGESTION:

Seek medical attention immediately. DO NOT induce vomiting.

EYES:

Irrigate immediately with water for several minutes. Although NOT a primary irritant, minor irritation may occur following contact.

Fire

Flash point 232°C. Not classified as flammable.

Suitable extinguishing media: CO₂, dry powder, foam or water fog. DO NOT use water jets.

Environment

WASTE DISPOSAL: Through authorised contractor to a licensed site. May be incinerated. Used product may be sent for reclamation.

SPILLAGE: Prevent entry into drains, sewers and water courses. Soak up with absorbent material.

Handling

Wear eye protection, impervious gloves (e.g. of PVC) and a plastic apron. Use in well ventilated area.

Storage

No special precautions.

Priming Procedure

I M P O R T A N T

**All operations should be carried out on a clean bench, with clean hands in a clean area.
Ensure that the oil is perfectly clean and free from air bubbles.
Care MUST be taken at all times, to ensure that no foreign matter enters the tool, or serious damage may result.
The tool must remain on its side throughout the priming sequence**

- Place tool on its side, Oil Plug **35** side up.
- With an Allen key, unscrew Oil Plug **35** and remove with Oil Seal Washer **36**.
- Fill tool with priming oil rocking gently to expel air.
- Replace Oil Seal Washer **36** and Oil Plug **35** and tighten.
- You must now bleed the tool. This operation is to ensure air bubbles are eliminated from the oil circuit.
- Ensuring oil Bleed Screw **10** is fully tightened unscrew by ONE TURN only, using an Allen key. Connect the tool to the air supply and depress the Trigger **40**.
- Wait until oil appears all around Oil Bleed Screw **10** then re-tighten. Wipe excess oil away.
- Release the Trigger **40**.
- Using an Allen Key remove Oil Plug **35** and Oil Seal Washer **36**.
- Top-up with priming oil to reset level. Replace Oil Seal Washer **36** and Oil Plug **35** and fully tighten.
- It is necessary to fit the appropriate nose equipment and adjust the tool stroke prior to operating the tool.

Item numbers in **bold** refer to general assembly drawings and parts list (pages 14-15).

Fault Diagnosis

Symptom	Possible Cause	Remedy	Page Ref
Pneumatic motor runs slowly	Air leak from motor	Check for worn seals. Replace	13
	Low air pressure	Increase	7
	Air way blockage	Clear restriction in air supply	
	Worn drive screw	Replace	8
	Vanes jamming	Lubricate tool through air inlet	
Insert does not deform properly	Force incorrectly set	Adjust	7
	Air pressure outside the tolerance	Adjust	7
	Low oil level	Prime tool	18
	Insert out of grip	Check grip range of Insert	
Drivescrew turns independent of motor	Worn or damaged drive shaft	Replace	
	Worn or damaged drive screw	Replace	8
	Adaptor nut loose	Tighten	8
	Locknut 6 missing	Fit new locknut	13
Insert will not place onto drivescrew	Incorrect Insert thread size	Change to correct insert	
	Incorrect drive screw fitted	Change to correct drive screw	
	Worn or damaged drive screw	Replace	
	Nose equipment incorrectly assembled	Disconnect air supply, re-fit nose equipment carefully	8-9
Tool is jammed on placed insert	Excessive force/ Defective insert/ Worn or defective drive screw	DO NOT DEPRESS TRIGGER. Unlock force locking device. Depress trigger. Tool should spin off. Reset force. If not, disconnect air to tool. Insert a 4 mm Ø pin through nose casing slots into Spindle Connector 3 . Turn until drive screw leaves. Insert. Use new insert AND drive screw.	
Drive screw breaks	Force of tool excessive	Re-set force	
	Side load on drive screw	Hold tool square to application when placing Insert	

continued overleaf

Item numbers in **bold** refer to general assembly drawings and parts list (pages 14-15).

Other symptoms or failures should be reported to your local TFS authorised distributor or repair centre.

Fault Diagnosis

Symptom	Possible Cause	Remedy	Page Ref
Tool does not spin on	Screw adaptor nut loose	Tighten	
	No air supply	Connect	7
	Insufficient gap between Locknut 6 and Spindle Connector 3	Adjust to 1.5 mm gap to 2mm gap	13
	Pushrod 17 too short	Replace	13
	Air motor jammed	Lubricate tool at air inlet. If insufficient dismantle and clean air motor thoroughly	
Trigger inoperative	Static friction	Depress trigger a few times	
	Low air pressure	Increase air pressure	
	Valve piston remains stuck	Depress trigger several times. Lubricate tool through air inlet. If unsuccessful, dismantle, clean and lubricate trigger elements	
Drivescrew does not return and/or keeps spinning off	Lip Seal 46 is defective	Replace	12
Tool does not spin off	Adaptor Nut 2 loose	Tighten	
	No air supply	Connect	
	Turn Regulator 93* half turn	Set tool force	7
	Distributor stuck	Lubricate	
	Air motor jammed	Lubricate tool at air inlet. If insufficient dismantle and clean air motor thoroughly	

Item numbers in **bold** refer to general assembly drawings and parts list (pages 14-15).

93* see page 16.

Other symptoms or failures should be reported to your local TFS authorised distributor or repair centre.

Declaration of Conformity

We, Textron Fastening Systems Limited, Mundells, Welwyn Garden City, Herts, AL7 1EZ
declare under our sole responsibility that the product:

Model Type 74201

Serial No.

to which this declaration relates is in conformity with the following standards:

EN292 part 1 and part 2	
ISO 8662 part 1	EN 60742/0695
ISO 3744	EN 50081-1
ISO PREN792 part 14	EN 55014

following the provisions of the Machine Directive 89/392/EC
(as amended by Directive 91/368/EC, 93/44/EC) and 93/68/EC



M. Delle Fave - Quality Manager

Welwyn Garden City - date of issue



**This box contains a power tool which is in
conformity with Machines Directive
89/392/EC. The 'Declaration of Conformity'
is contained within.**

TEXTRON Fastening Systems

Avdel® Blind Fastening & Automation Systems

AUSTRALIA

Textron Fastening Systems Pty Ltd

891 Wellington Road
Rowville
Victoria 3178
Tel: +613 9765 6400
Fax: +613 9765 6445
Email: custserv@textronfast.com.au

CANADA

Avdel Division of Textron Canada Ltd

87 Disco Road
Rexdale
Ontario M9W 1M3
Tel: +1 416 679 0622
Fax: +1 416 679 0678
Email: info@tfs.textron.com

CHINA

Textron Fastening Systems China Ltd

Room 1708 Nanyang Plaza
57 Hung To Road
Kwun Tong
Kowloon
Hong Kong
Tel: +852 2950 0630
Fax: +852 2950 0022
Email: tfschina@tfschina.com

FRANCE

Avdel® s.a.

33 bis, rue des Ardennes
BP4, 75921 Paris Cédex 19
Tel: +33 1 4040 8000
Fax: +33 1 4040 8040
Email: avpcom@tfs.textron.com

GERMANY

Textron Verbindungstechnik GmbH

Klusriede 24
D - 30851 Langenhagen
Tel: +49 511 7288 0
Fax: +49 511 7288 133
Email: info@avdel.de

ITALY

Textron Sistemi di Fissaggio SRL

Via Manin 350-21
It- 20099 Sesto San Giovanni
Milano
Tel: +39 02 262 9171
Fax: +39 02 242 4956
Email: tfs@tfsitalia.com

JAPAN

Avdel Kabushiki Kaisha

7F, New Erimo Building,
2-2-1, Senba Nishi,
Mino, Osaka 562-0036
Tel: +81 727 30 0838
Fax: +81 727 30 0837
Email: webadm@avdel.co.jp

SOUTH KOREA

Textron Fastening Systems Korea

583-1 Munhyung-Ri
Opo-Eup Kwangju-City
Kyunggi-Do
Korea 464-890
Tel: +82 31 767 4667~9
Fax: +82 2 3471 8917
Email: paul@tfskorea.com

SPAIN

Textron Sistemas de Fijación S.A.

c/ Puerto de la Morcuera, s/n
Poligono Industrial Prado Overa
Autovia Madrid Toledo Km 7.8
Es - 28916 Leganes (Madrid)
Tel: +349 134 16767
Fax: +349 134 16740
Email: ventas@tfs.textron.com

UNITED KINGDOM

Textron Fastening Systems Ltd

Pacific House
2 Swiftfields
Watchmead Industrial Estate
Welwyn Garden City
Hertfordshire
AL7 1LY
Tel: +44 1707 292000
Fax: +44 1707 292199
Email: enquiries@tfs.textron.com

USA

Avdel Cherry Textron Inc.

614 NC Highway 200 South
Stanfield,
North Carolina 28163
Tel: +1 704 888-7100
Fax: +1 704 888-0258
Email: info@tfsi.textron.com

Textron Fastening Systems HQ

840 West Long Lake Road
Troy, MI 48098
Tel: +1 800 544 6117
Fax: +1 815 961 5345

© TEXTRON FASTENING SYSTEMS
PRINTED 06/10/2005

Manual No.	Issue	Change Note No.	Date
07900-00XXX	AA	xx/xxx	11-01

Textron Fastening Systems Inc. is a subsidiary of Textron Inc. Avdel®, Avdel® SR, Hexsert®, Standard Nutsert®, Supersert®, Squaresert®, Thin Sheet Nutsert®, are trademarks of Textron Inc.